



Model EPZ-13C-THG 355nm Compact Zoom Beam Expander

Magnification adjusts from 1X to 3X

GEOMATEC Brand Beam Expanders

Designed for High Performance Laser System Applications based on 1064, 532 and 355nm Wavelengths, GEOMATEC Beam Expanders offer the laser system integrator superior performance, high quality and excellent uniformity from unit to unit, in one of the smallest packages found in the industry. GEOMATEC high quality coatings and meticulous manufacturing and quality standards produce a highly reliable unit you can depend on for your laser system.

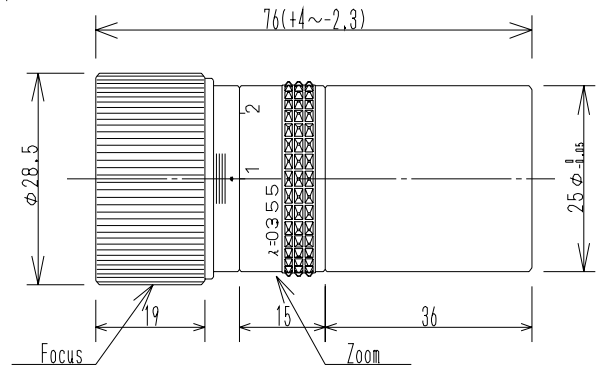

Model #	EPZ-13C-THG
Wavelength:	355nm
Expansion Ratio:	1x to 3x
Input Beam Diameter:	at 1x: 8.0mm, at 3x: 4.0mm
Output Beam Diameter:	at 1x: 8.0mm, at 3x: 12.0mm
Damage Threshold:	$\geq 10\text{MW/cm}^2$, 10ns pulses
Transmittance:	$\geq 96\%$

All dimensions in millimeters unless specified otherwise, specifications subject to change without notice.

BeamExpander.com LLC, 362 University Avenue, Westwood, MA, 02090 Tel: 781-255-1063